

s12594

CREATED ON
2022-04-11



Total area 137.99 m ²	Floors 4	Rooms 12	Bathroom 1
--	--------------------	--------------------	----------------------

▼ **Basement**

TOTAL AREA: 17.10 m² • LIVING AREA: 0.00 m² • ROOMS: 1

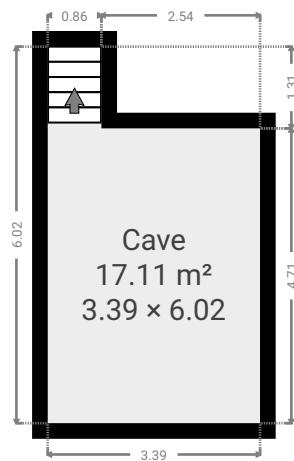

▼ Cave
Basement

WIDTH: 3.39 m • LENGTH: 6.02 m
AREA: 17.11 m² • PERIMETER: 18.82 m

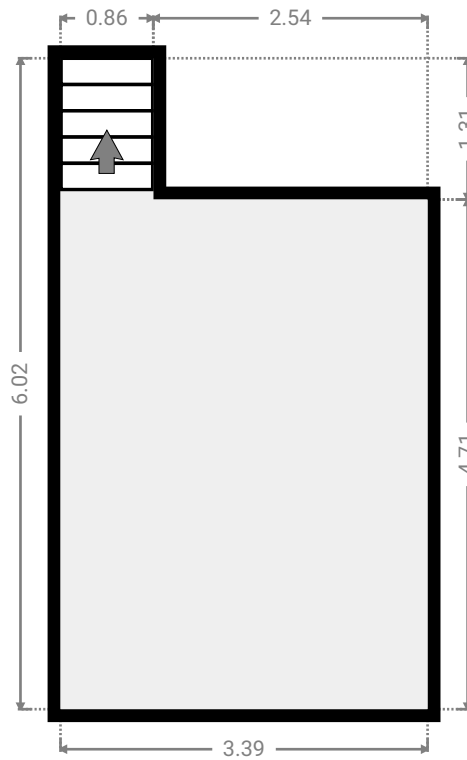
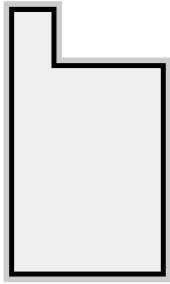

▼ Ground Floor

TOTAL AREA: 76.12 m² • LIVING AREA: 36.39 m² • ROOMS: 6

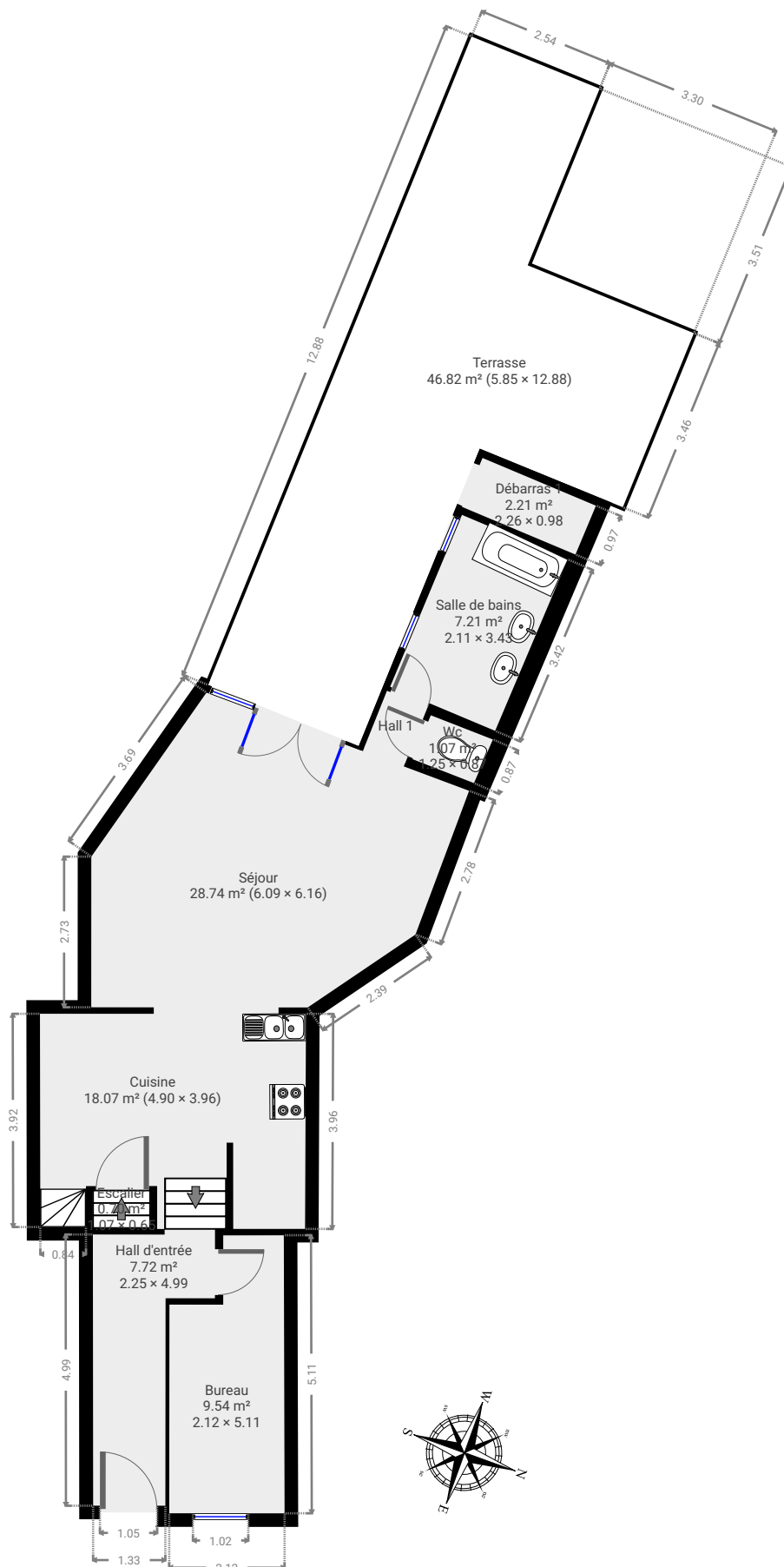

▼ **Hall d'entrée**
Ground Floor

WIDTH: 2.25 m • LENGTH: 4.99 m
AREA: 7.72 m² • PERIMETER: 14.46 m

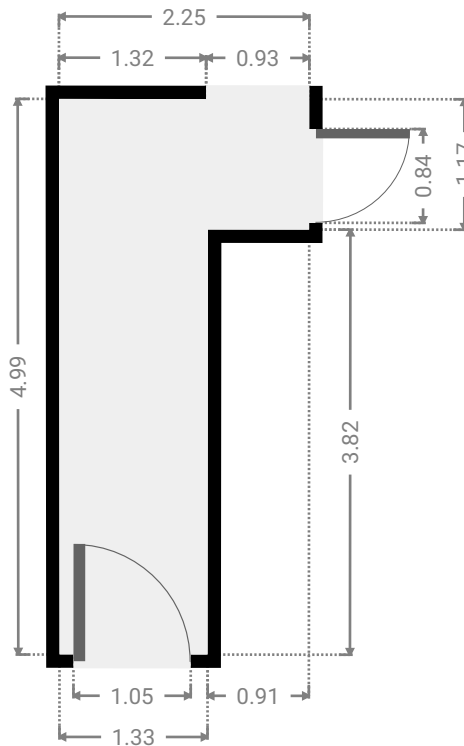
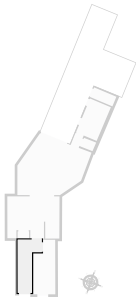

▼ **Bureau**
Ground Floor

WIDTH: 2.12 m • LENGTH: 5.11 m
AREA: 9.54 m² • PERIMETER: 14.46 m

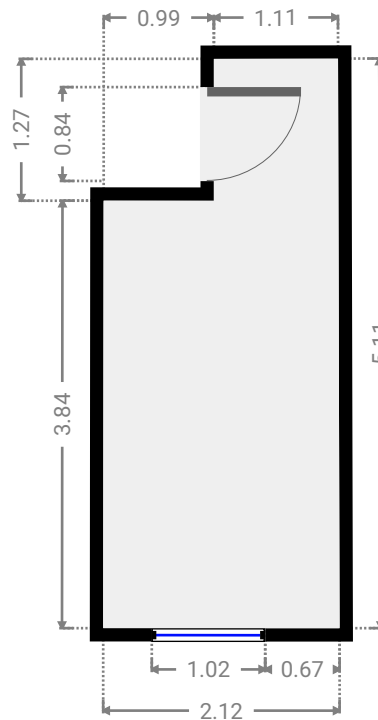

▼ Cuisine
Ground Floor

WIDTH: 4.90 m • LENGTH: 3.96 m
AREA: 18.07 m² • PERIMETER: 22.36 m

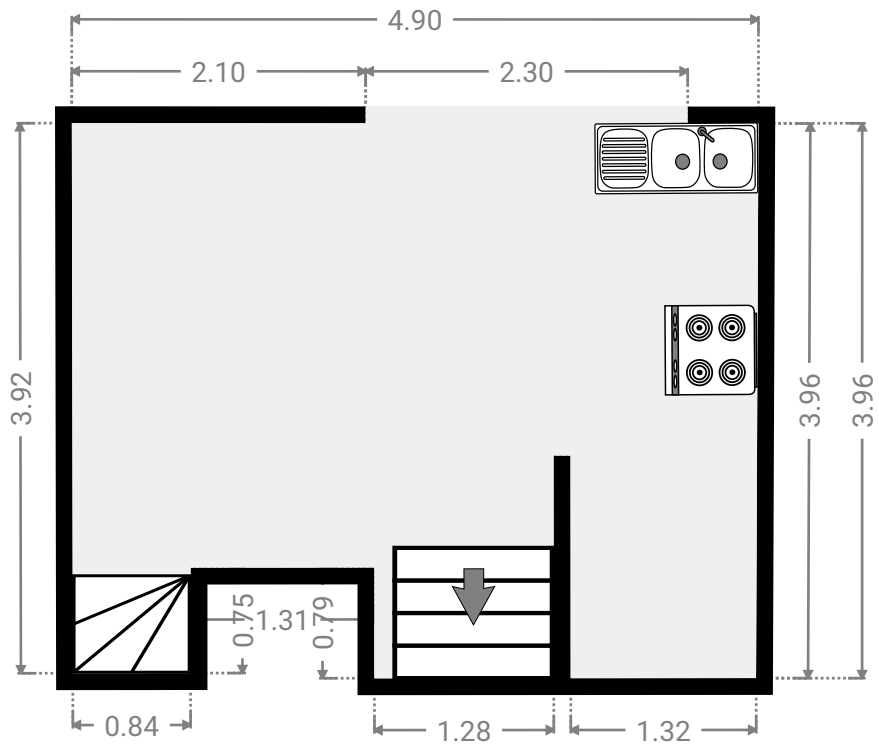
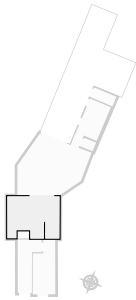

▼ Escalier
Ground Floor

WIDTH: 1.07 m • LENGTH: 0.65 m
AREA: 0.70 m² • PERIMETER: 3.44 m

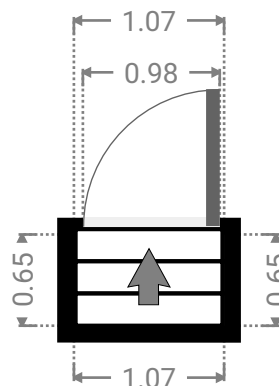
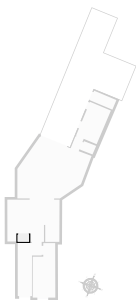

▼ **Séjour**
Ground Floor

WIDTH: 6.09 m • LENGTH: 6.16 m
AREA: 28.74 m² • PERIMETER: 20.82 m

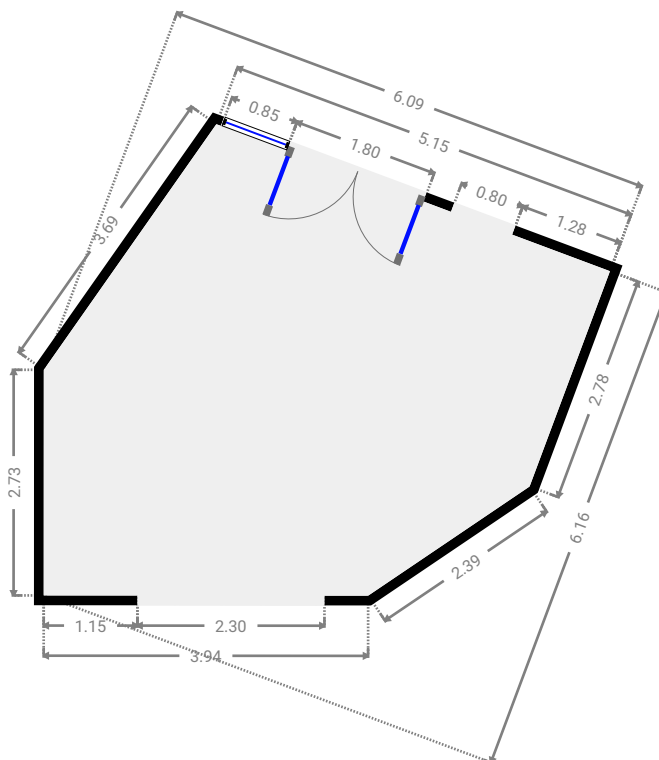
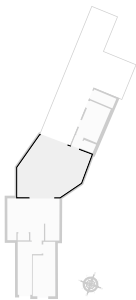

▼ **Hall 1**
Ground Floor

WIDTH: 0.81 m • LENGTH: 1.13 m
AREA: 0.91 m² • PERIMETER: 3.86 m

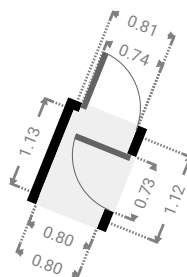
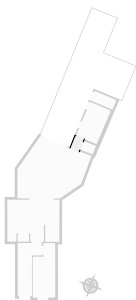

▼ **Wc**
Ground Floor

WIDTH: 1.25 m • LENGTH: 0.87 m
AREA: 1.07 m² • PERIMETER: 4.19 m

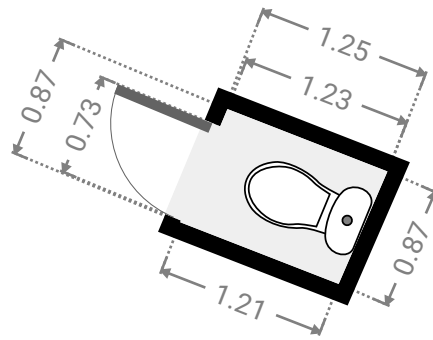
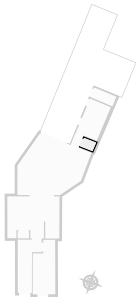

▼ **Salle de bains**
Ground Floor

WIDTH: 2.11 m • LENGTH: 3.43 m
AREA: 7.21 m² • PERIMETER: 11.06 m

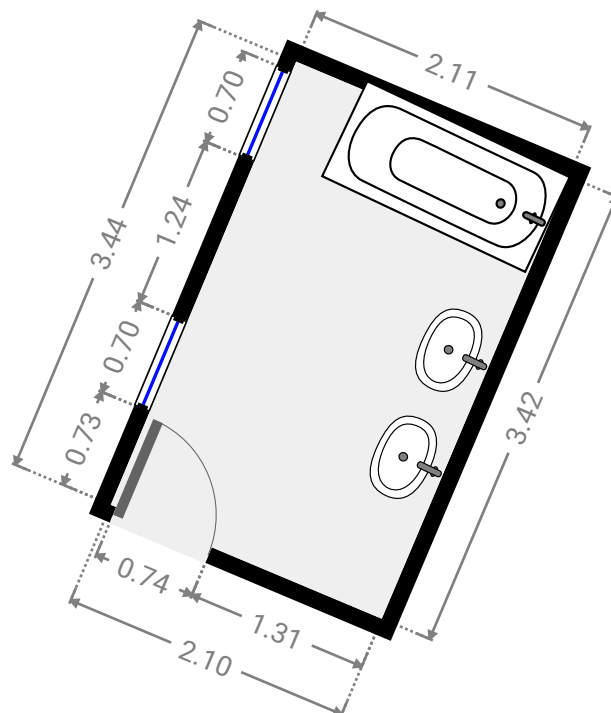
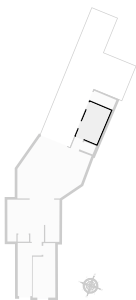

▼ **Terrasse**
Ground Floor

WIDTH: 5.85 m • LENGTH: 12.88 m
AREA: 46.82 m² • PERIMETER: 37.44 m

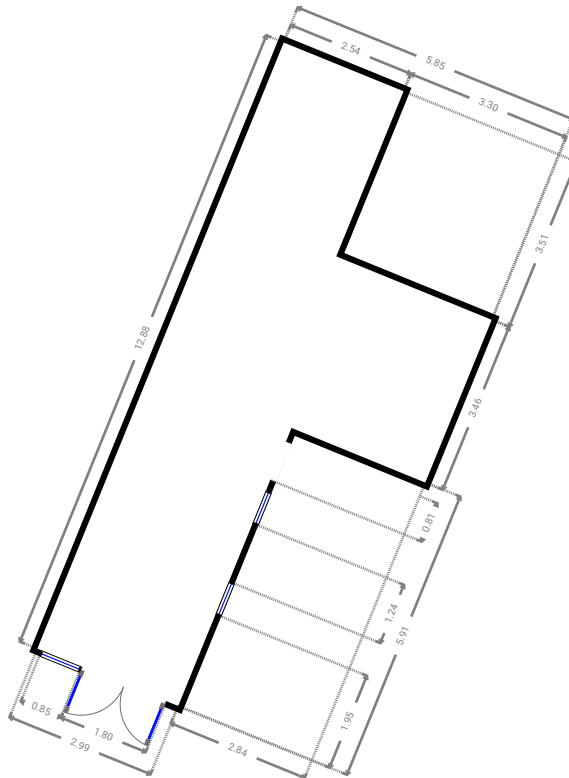
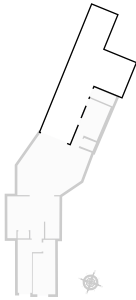

▼ **Débarras 1**
Ground Floor

WIDTH: 2.26 m • LENGTH: 0.98 m
AREA: 2.21 m² • PERIMETER: 6.48 m

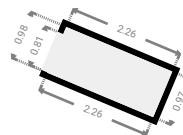
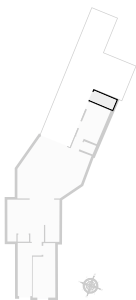

▼ 1st Floor

TOTAL AREA: 35.98 m² • LIVING AREA: 31.19 m² • ROOMS: 4

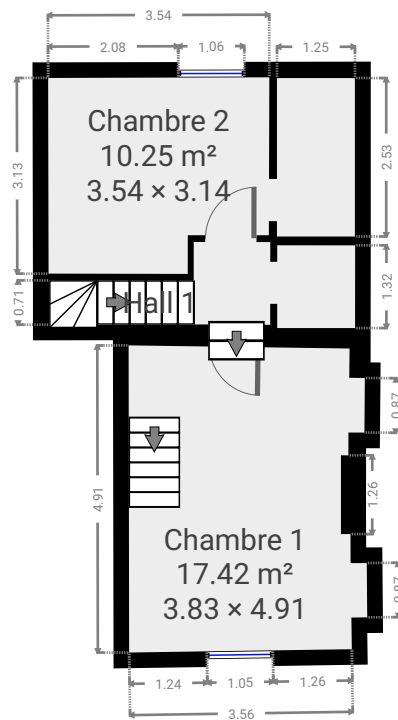

▼ **Chambre 1**
1st Floor

WIDTH: 3.83 m • LENGTH: 4.91 m
AREA: 17.42 m² • PERIMETER: 18.09 m

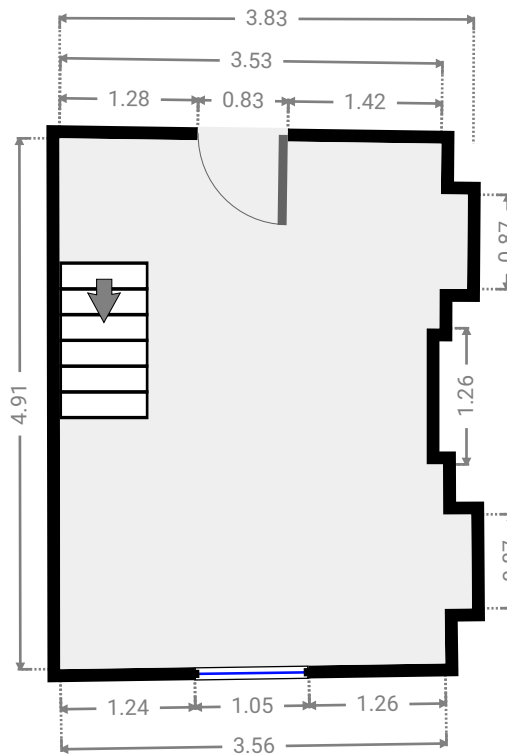
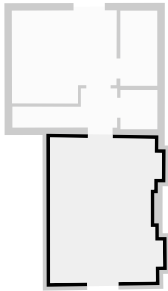

▼ **Hall 1**
1st Floor

WIDTH: 3.53 m • LENGTH: 1.76 m
AREA: 3.60 m² • PERIMETER: 10.58 m

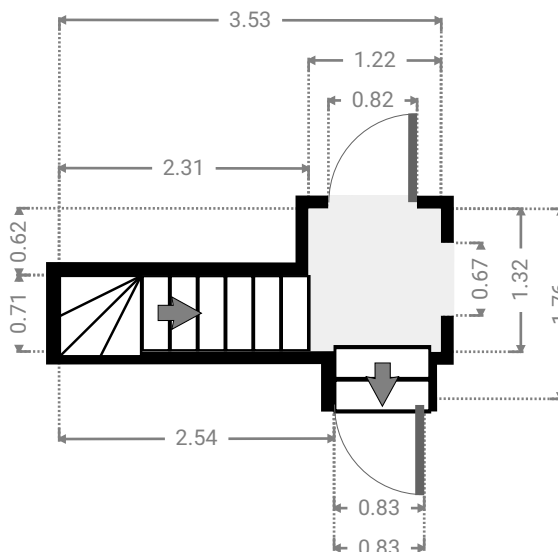
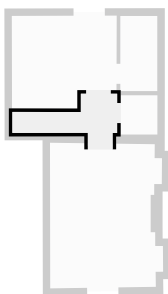

▼ **Chambre 2**
1st Floor

WIDTH: 3.54 m • LENGTH: 3.14 m
AREA: 10.25 m² • PERIMETER: 13.32 m

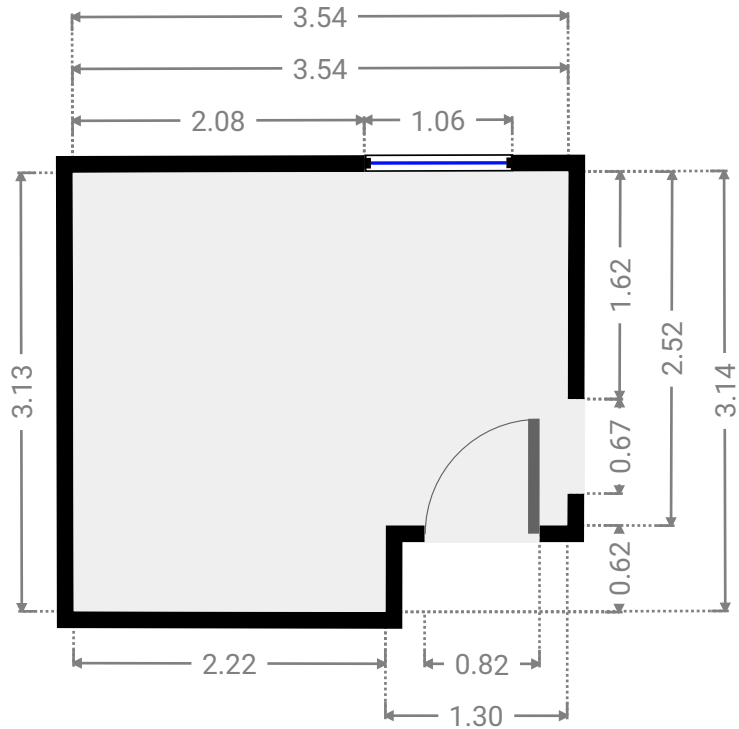
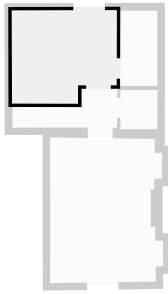

▼ **Débarras 2**
1st Floor

WIDTH: 1.24 m • LENGTH: 1.32 m
AREA: 1.65 m² • PERIMETER: 5.13 m

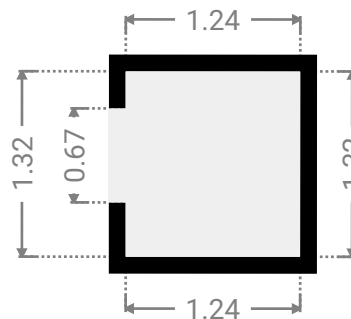
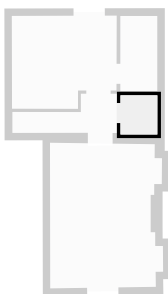

▼ **Dressing**
1st Floor

WIDTH: 1.25 m • LENGTH: 2.53 m
AREA: 3.15 m² • PERIMETER: 7.55 m

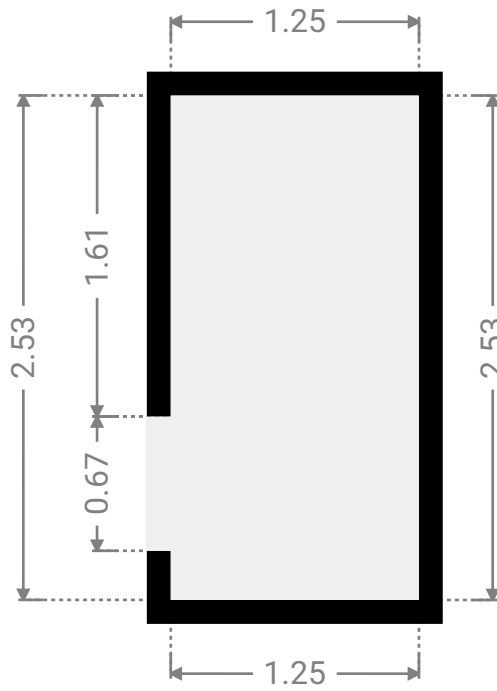
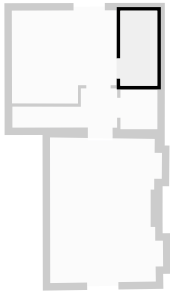

▼ 2nd Floor

TOTAL AREA: 8.79 m² • LIVING AREA: 0.00 m² • ROOMS: 1

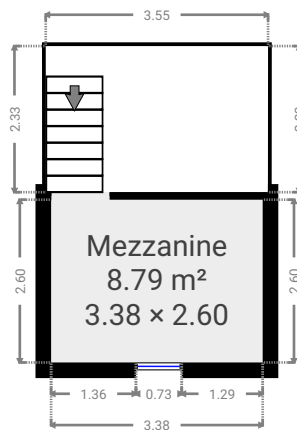

▼ Mezzanine
2nd Floor

WIDTH: 3.38 m • LENGTH: 2.60 m
AREA: 8.79 m² • PERIMETER: 11.96 m

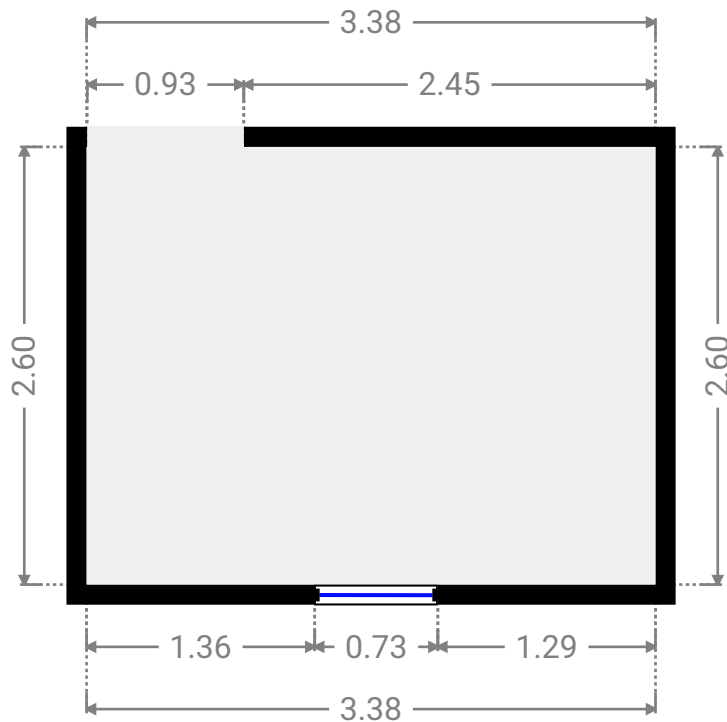
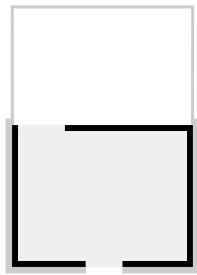

▼ Ouvert sur chambre 1
2nd Floor

WIDTH: 3.55 m • LENGTH: 2.33 m
AREA: 8.29 m² • PERIMETER: 11.77 m

