

# s26188

CRÉÉ LE  
2025-07-08

<b>Surface totale</b> 155.50 m <sup>2</sup>	<b>Étages</b> 4	<b>Pièces</b> 15	<b>Salle de bains</b> 0
--	--------------------	---------------------	----------------------------

▼ Rez-de-chaussée

SURFACE TOTALE : 47.32 m<sup>2</sup> • SURFACE HABITABLE : 39.93 m<sup>2</sup> • PIÈCES : 6

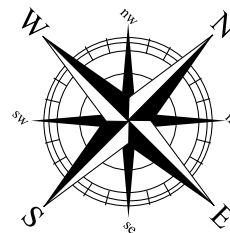
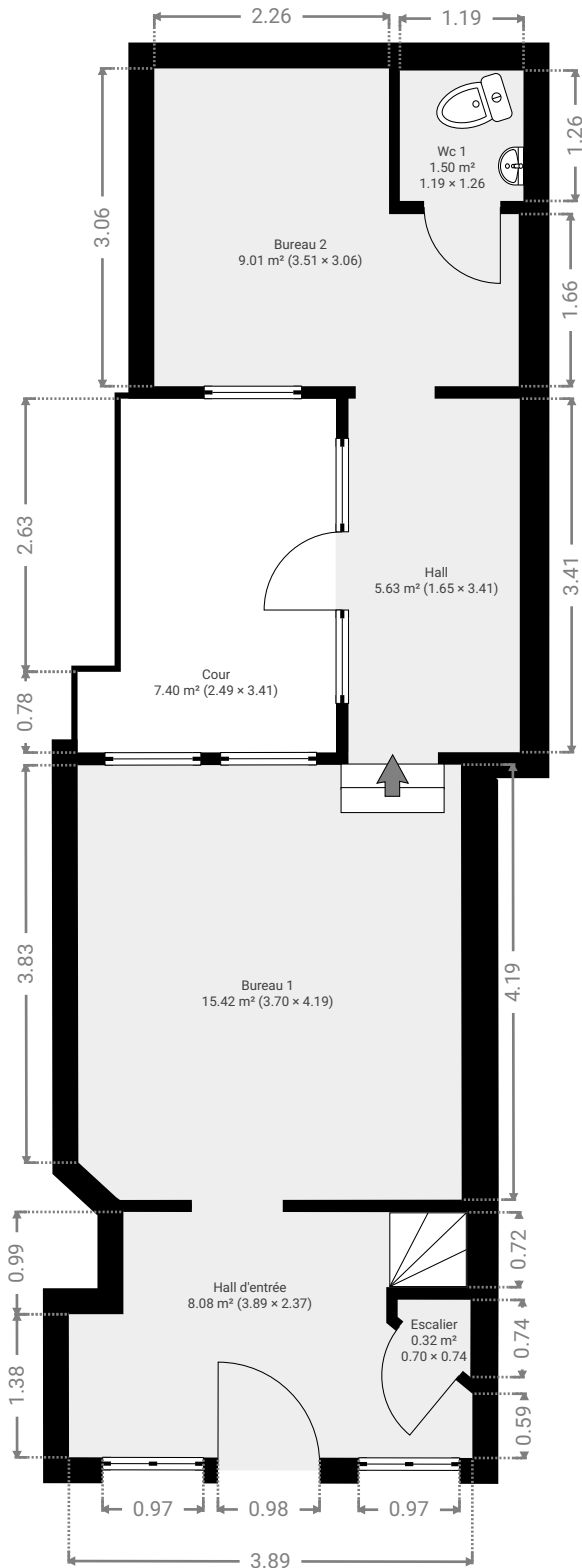

▼ **Bureau 1**  
Rez-de-chaussée

LARGEUR : 3.70 m • LONGUEUR : 4.19 m  
SURFACE : 15.42 m<sup>2</sup> • PÉRIMÈTRE : 15.56 m

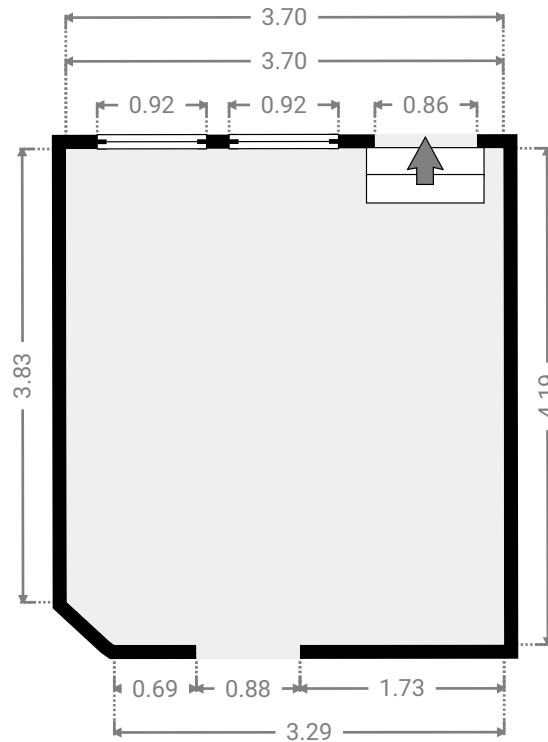
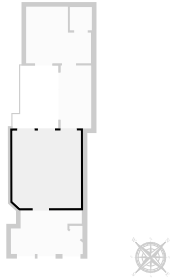

▼ **Bureau 2**  
Rez-de-chaussée

LARGEUR : 3.51 m • LONGUEUR : 3.06 m  
SURFACE : 9.01 m<sup>2</sup> • PÉRIMÈTRE : 13.15 m

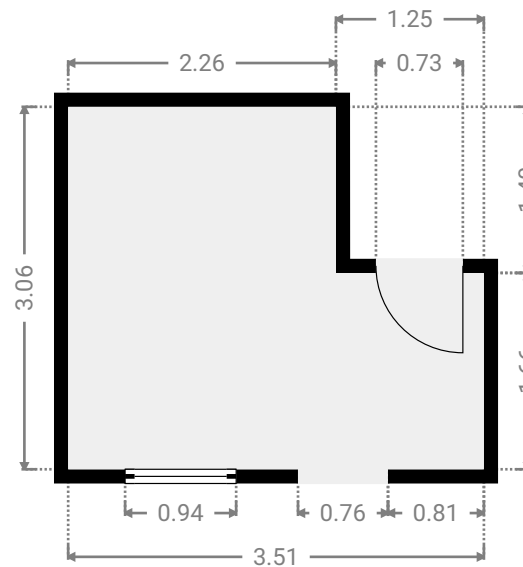
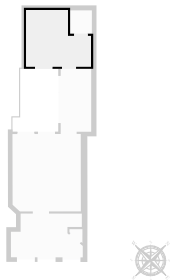

▼ Cour  
Rez-de-chaussée

LARGEUR : 2.49 m • LONGUEUR : 3.41 m  
SURFACE : 7.40 m<sup>2</sup> • PÉRIMÈTRE : 11.81 m

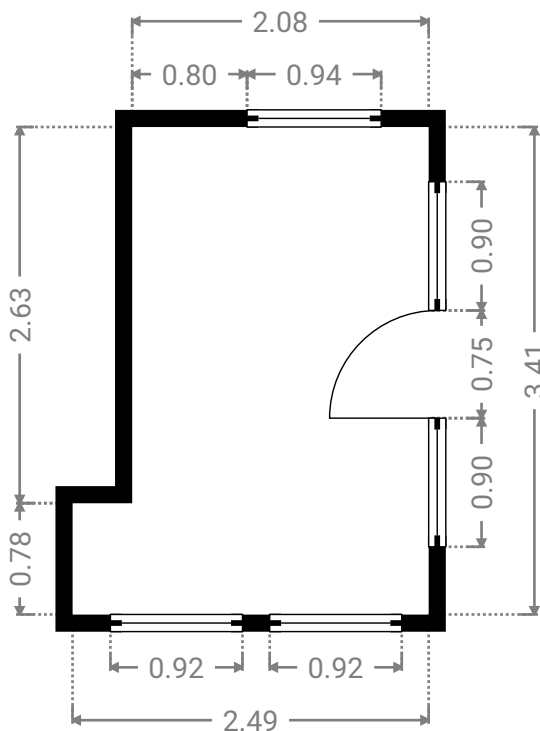
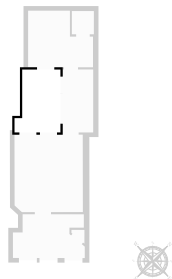

▼ Escalier  
Rez-de-chaussée

LARGEUR : 0.70 m • LONGUEUR : 0.74 m  
SURFACE : 0.32 m<sup>2</sup> • PÉRIMÈTRE : 2.52 m

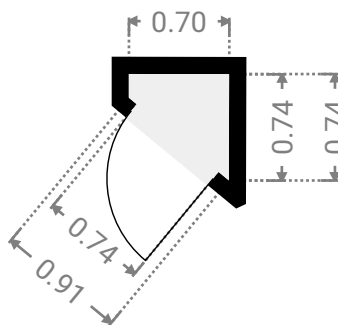
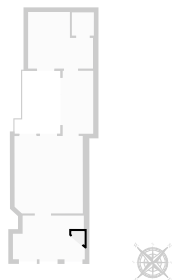

▼ **Hall**  
Rez-de-chaussée

LARGEUR : 1.65 m • LONGUEUR : 3.41 m  
SURFACE : 5.63 m<sup>2</sup> • PÉRIMÈTRE : 10.12 m

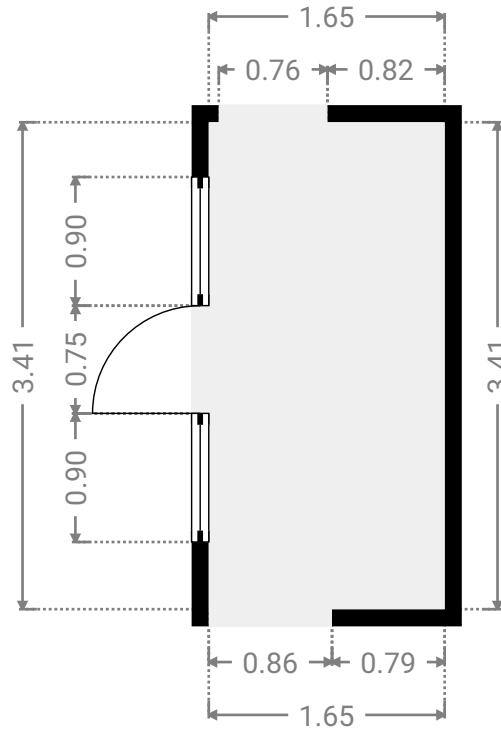
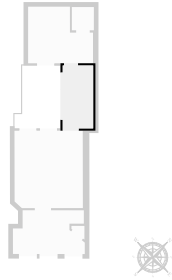

▼ **Hall d'entrée**  
Rez-de-chaussée

LARGEUR : 3.89 m • LONGUEUR : 2.37 m  
SURFACE : 8.08 m<sup>2</sup> • PÉRIMÈTRE : 13.64 m

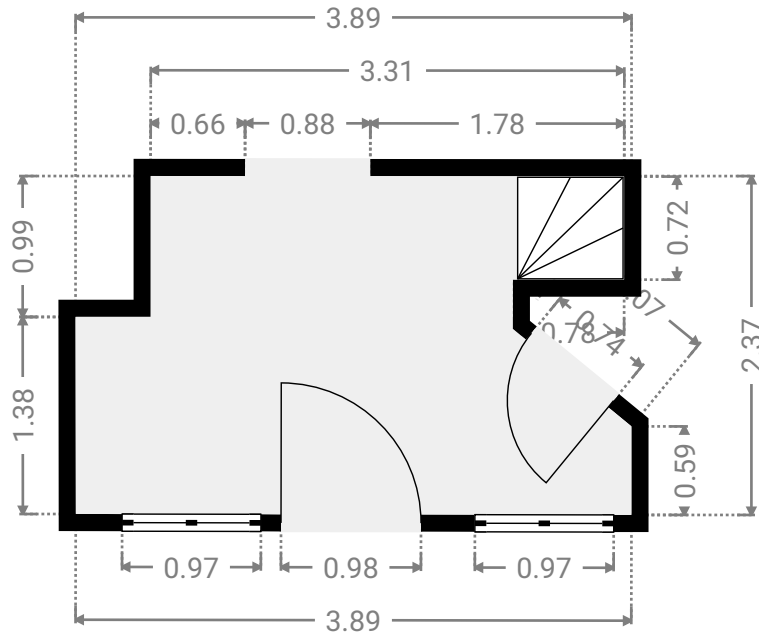
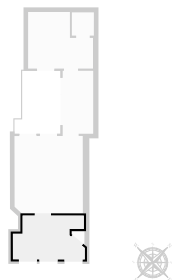

▼ **Wc 1**  
Rez-de-chaussée

LARGEUR : 1.19 m • LONGUEUR : 1.26 m  
SURFACE : 1.50 m<sup>2</sup> • PÉRIMÈTRE : 4.90 m

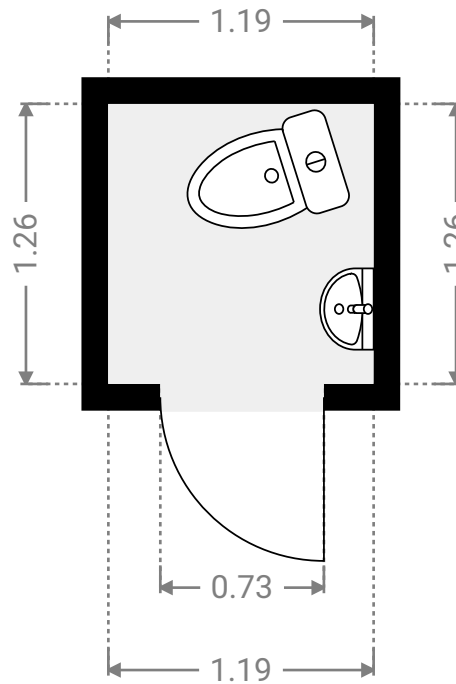
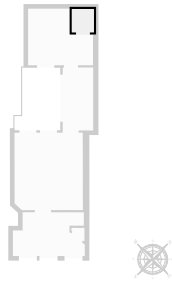



▼ **Buanderie**  
1er étage

LARGEUR : 2.11 m • LONGUEUR : 3.40 m  
SURFACE : 5.33 m<sup>2</sup> • PÉRIMÈTRE : 10.71 m

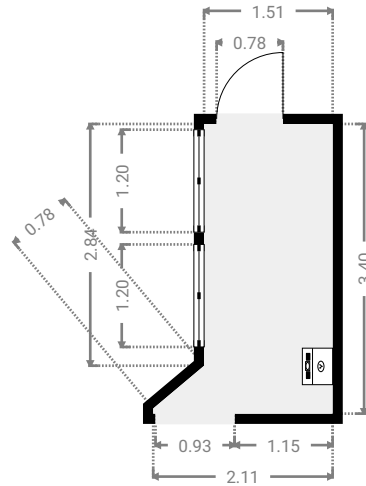
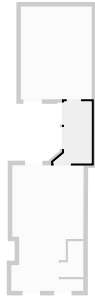

▼ **Cuisine**  
1er étage

LARGEUR : 3.96 m • LONGUEUR : 6.91 m  
SURFACE : 23.94 m<sup>2</sup> • PÉRIMÈTRE : 25.20 m

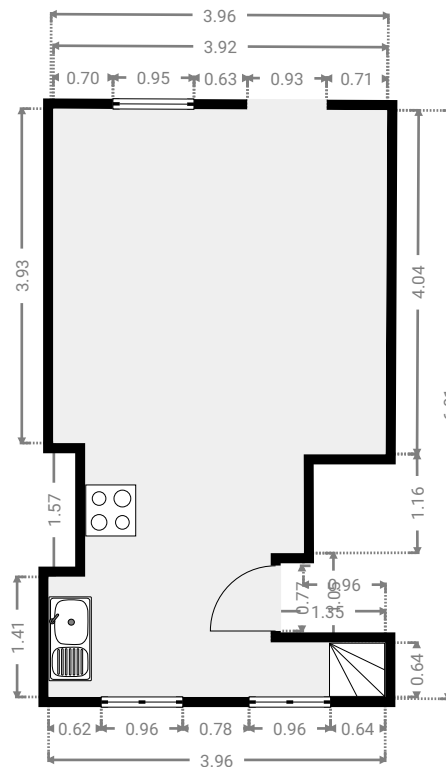
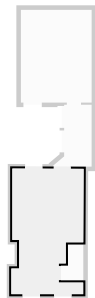



▼ Escalier  
1er étage

LARGEUR : 1.23 m • LONGUEUR : 1.98 m  
SURFACE : 1.98 m<sup>2</sup> • PÉRIMÈTRE : 6.42 m

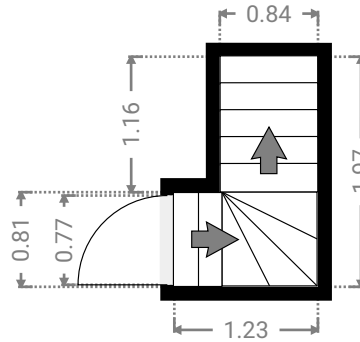

▼ Séjour  
1er étage

LARGEUR : 3.89 m • LONGUEUR : 5.10 m  
SURFACE : 19.86 m<sup>2</sup> • PÉRIMÈTRE : 17.99 m

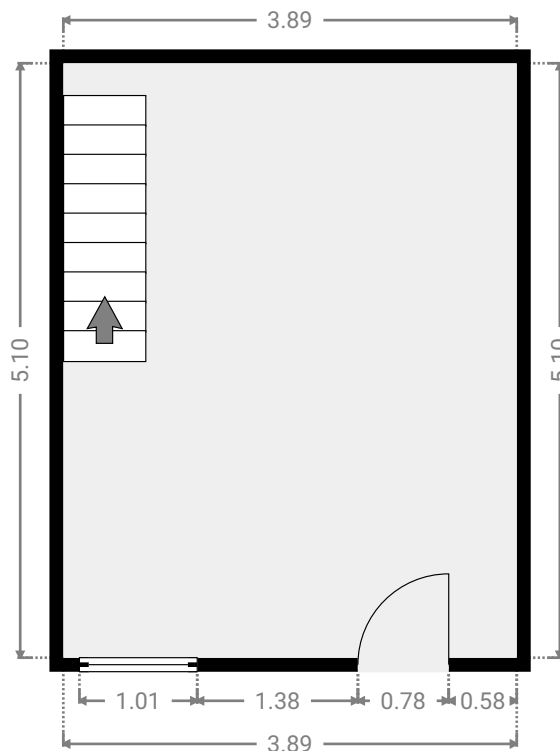
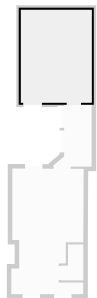

▼ 2e étage

SURFACE TOTALE : 39.51 m<sup>2</sup> • SURFACE HABITABLE : 29.03 m<sup>2</sup> • PIÈCES : 4

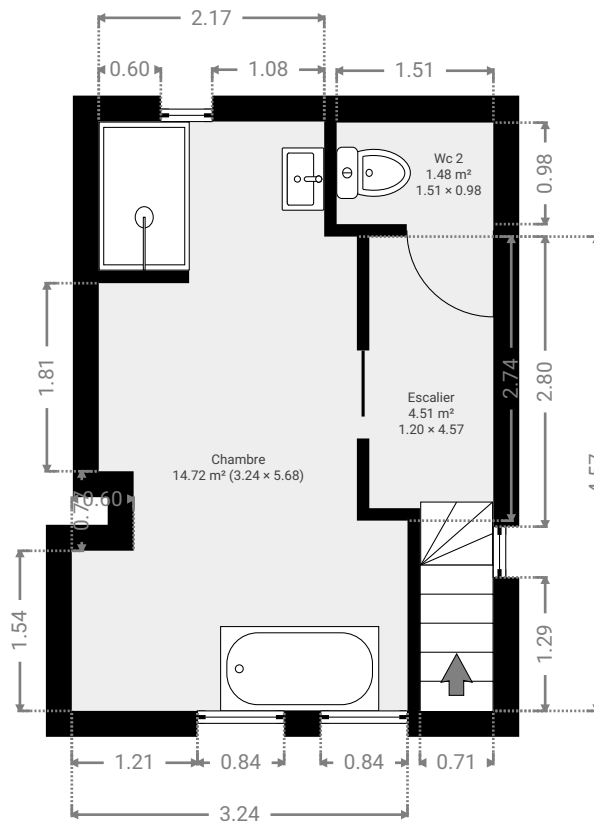
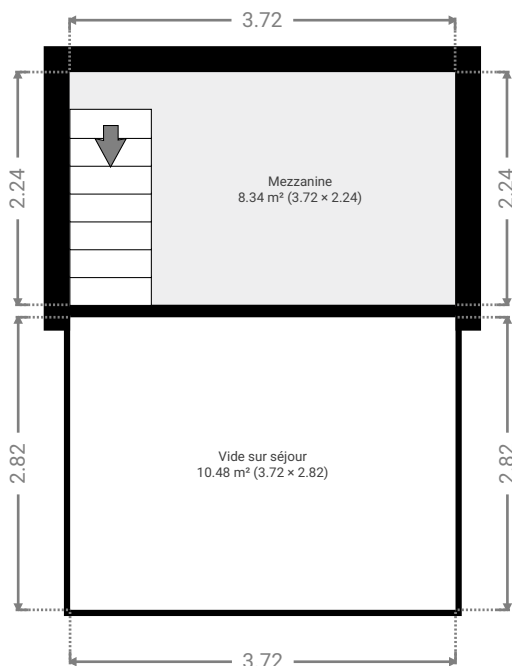

▼ **Chambre**  
2e étage

LARGEUR : 3.24 m • LONGUEUR : 5.68 m  
SURFACE : 14.72 m<sup>2</sup> • PÉRIMÈTRE : 20.25 m

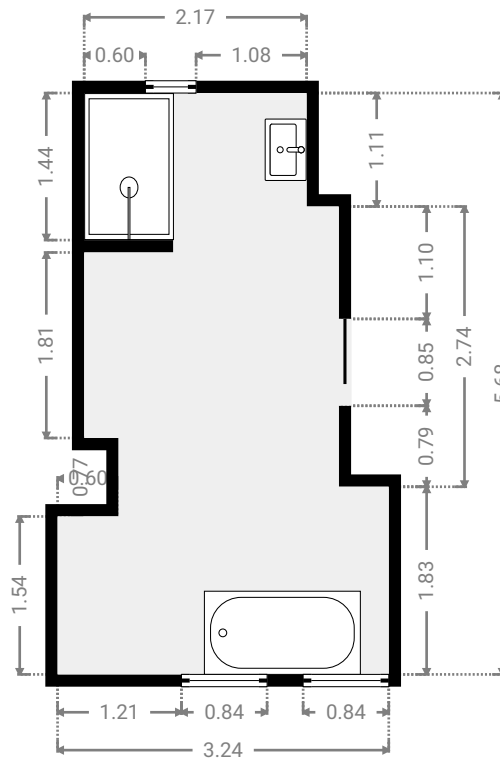
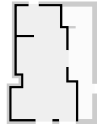

▼ **Escalier**  
2e étage

LARGEUR : 1.20 m • LONGUEUR : 4.57 m  
SURFACE : 4.51 m<sup>2</sup> • PÉRIMÈTRE : 11.53 m

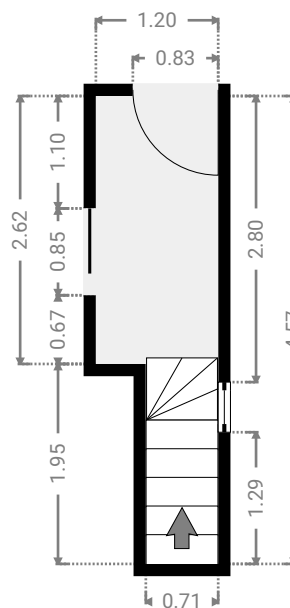
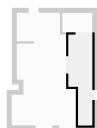
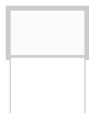

▼ Mezzanine  
2e étage

LARGEUR : 3.72 m • LONGUEUR : 2.24 m  
SURFACE : 8.34 m<sup>2</sup> • PÉRIMÈTRE : 11.92 m

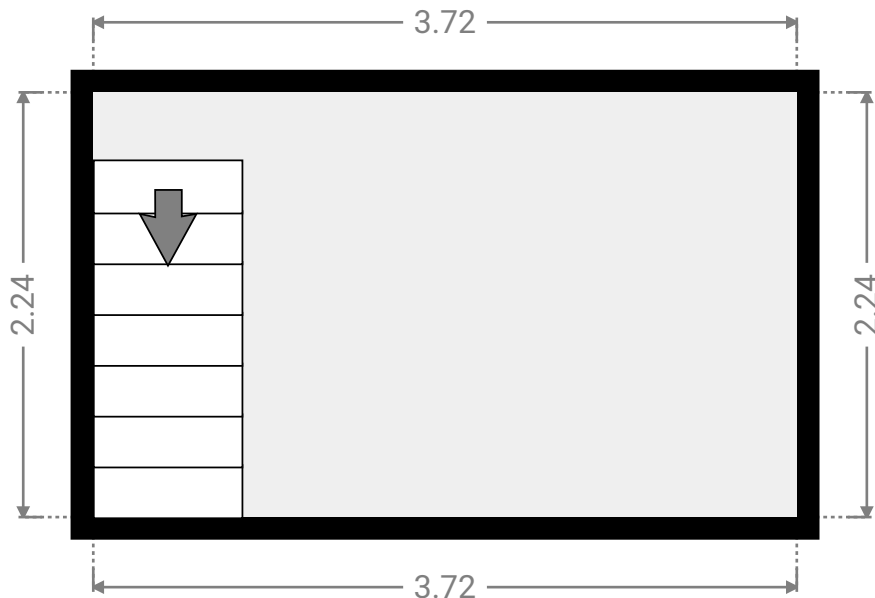

▼ Vide sur séjour  
2e étage

LARGEUR : 3.72 m • LONGUEUR : 2.82 m  
SURFACE : 10.48 m<sup>2</sup> • PÉRIMÈTRE : 13.07 m

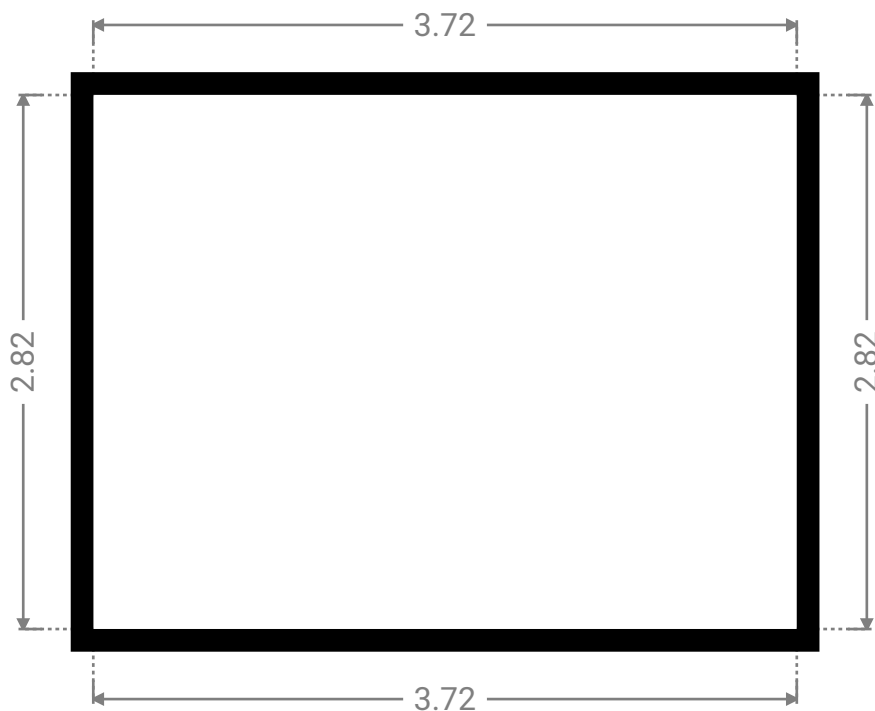
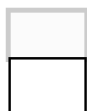

▼ **Wc 2**  
2e étage

LARGEUR : 1.51 m • LONGUEUR : 0.98 m  
SURFACE : 1.48 m<sup>2</sup> • PÉRIMÈTRE : 4.98 m

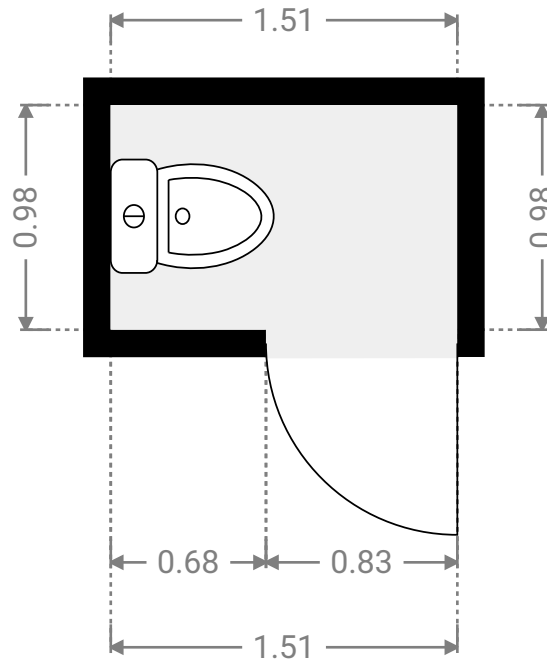

▼ **Sous-sol**

SURFACE TOTALE : 17.58 m<sup>2</sup> • SURFACE HABITABLE : 17.58 m<sup>2</sup> • PIÈCES : 1

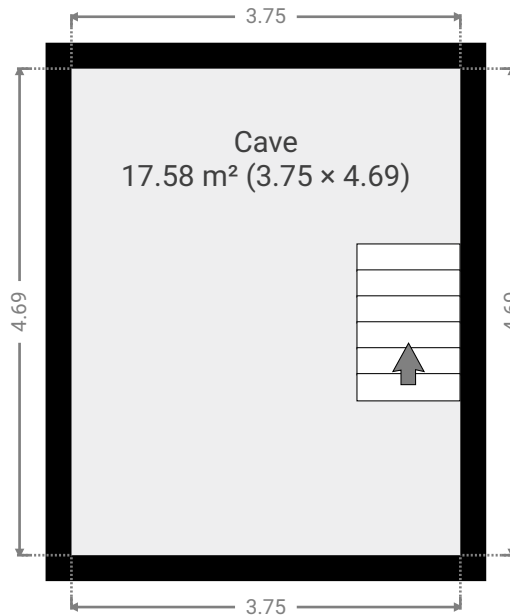

▼ **Cave**  
Sous-sol

LARGEUR : 3.75 m • LONGUEUR : 4.69 m  
SURFACE : 17.58 m<sup>2</sup> • PÉRIMÈTRE : 16.88 m

